

Schematic Diagram Of System Installation

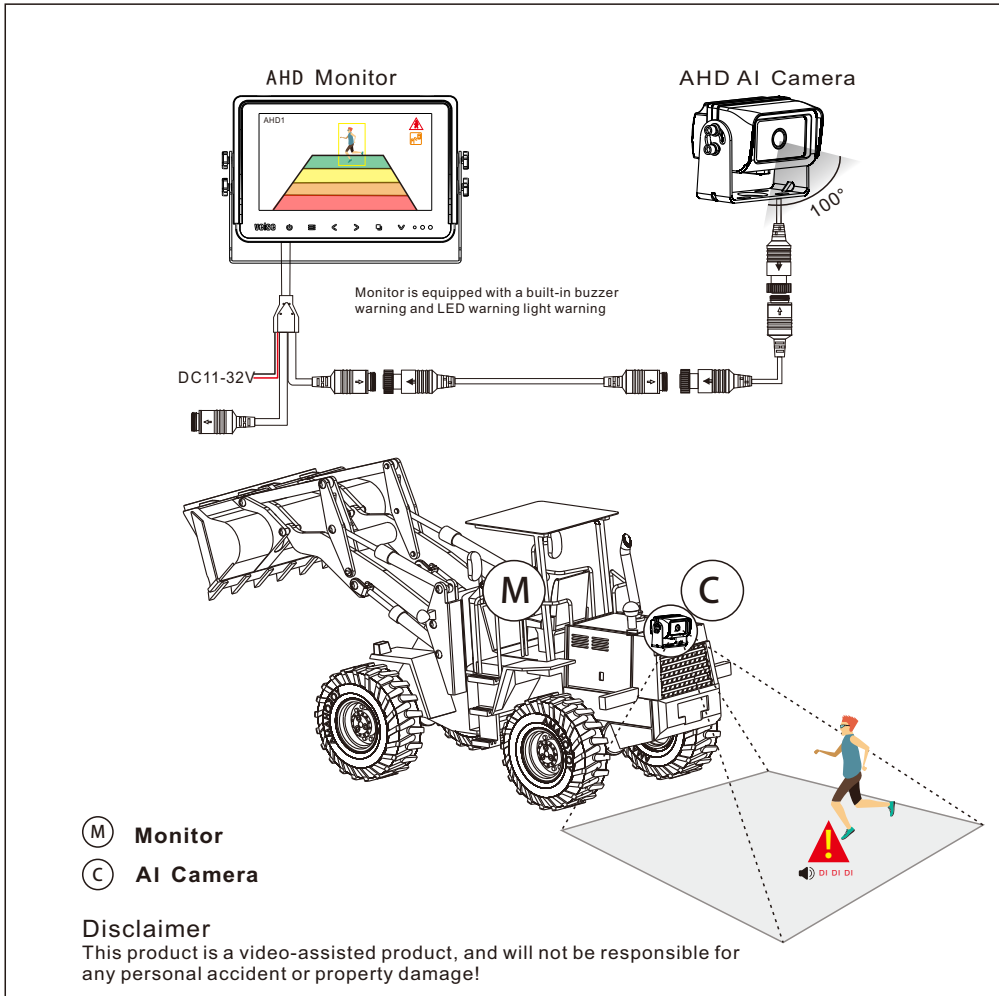

⚠ CAVEAT

Maintenance of this system must be maintained by professionals, please do not open and improve the system at will!
This product system is only used as a safety visual aid for vehicle mechanical equipment operation, and is not responsible for safety accidents!
This manual is for reference only and is subject to change without notice. The final interpretation is owned by !

AI Pedestrian & Vehicle Detecting Audible And Visual Alarm Camera System



AI-powered



DI-DI-DI



LED



Warning

Thank you very much for purchasing our company's vehicle and mechanical equipment operation visual safety assistant system for users. Improve work efficiency and safety of personnel machinery, we strictly follow IATF/16949 quality Management system, the product uses industrial grade raw material design, advanced detection equipment provides reliable Sex and stability. Products meet China's MA, Europe and the United States FCC, CE, E-MARK, Japan and other international standards.



IATF/16949 : 2016



ISO 9001:2016



System Overview

Due to the high concentration required by vehicle and machinery operators, often do not have the time to constantly monitor the vehicle's rearview monitor image screen. This is especially true in situations where no reverse radar warning system is installed. During vehicle operation, this can easily create safety hazards for personnel, leading to economic losses.

The AI pedestrian detection warning rearview system not only eliminates the need for the complex wiring and installation of reverse radar, but also allows the AI human shape analysis camera to capture personnel in the monitoring area in realtime, unlike ordinary cameras. It sends warning signals that trigger the built-in buzzer alarm and LED strobe light alerts on the monitor to remind the driver, thus enhancing vehicle operation efficiency, eliminating safety hazards, and preventing economic losses. This system is widely used in trucks, forklifts, buses, and construction vehicles.

Product Features

- ★ 7-inch Monitor IPS screen with fast response speed, wide viewing angles, true colors;
- ★ HD Monitor protective glass panel and screen adopt a space free fully bonded process structure, eliminate specular reflection to ensure clear and transparent image screen. with touch button
- ★ HD Monitor resolution of 1024RGBx600, Supports 2 CH video input.
- ★ HD Monitor built-in audible and visual alarm to remind the driver for safety alerts.
- ★ HD Monitor free operating voltage input DC11V-32V for vehicles and mechanical equipment;
- ★ HD Monitor built-in power reverse polarity protection circuit to effectively prevent the human error "+ -"
- ★ HD Monitor built-in back light constant voltage constant current circuit for service life is extended;
- ★ Monitor OSD menu can set AHD1/AHD2 channel screen to flip up and down;
- ★ Monitor OSD menu can set AHD1/AHD2 channel reverse trigger image delay time 0-30s;
- ★ Monitor OSD menu can set AHD1/AHD2 channel reverse ruler on/off to assist safe operation of reverse;
- ★ HD Monitor compact structure seismic resistance level with GB/T 2423.10-2008 standard;
- ★ AI humanoid analysis backup camera is based on cloud based intelligent recognition algorithms, which can learn and recognize specific body movements of individuals, It can accurately identify humans in complex environments and is mainly used to monitor whether there are people entering areas where entry is prohibited some body movements of personnel entering or specific areas, and issuing level four warning signals to push to relevant monitoring systems;
- ★ Image distance measurement: 2 meters (customizable within 0-5 meters);
- ★ The AI camera adopts a 1/2.9 color cmos sensor;
- ★ Resolution: 1920 (H) X1080P (V), effective pixels: 200W;
- ★ Visual angle (horizontal) 100 ° ultra wide angle, vehicle grade solution;
- ★ AI function: pedestrian and vehicle intelligent recognition algorithms detect and predict;
- ★ AI camera IO port outputs alarm signal;
- ★ The camera casing is made of aluminum alloy material;
- ★ Camera anti fog and waterproof level IP69K;



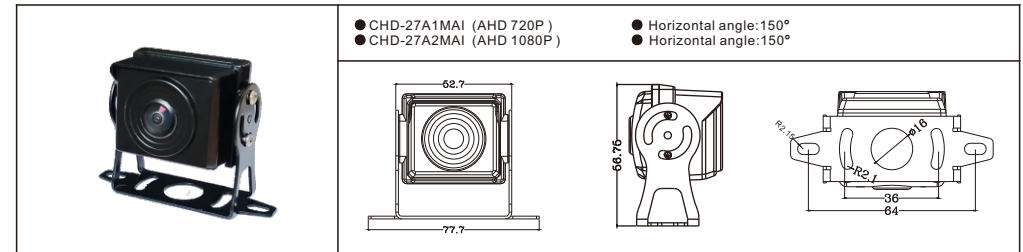
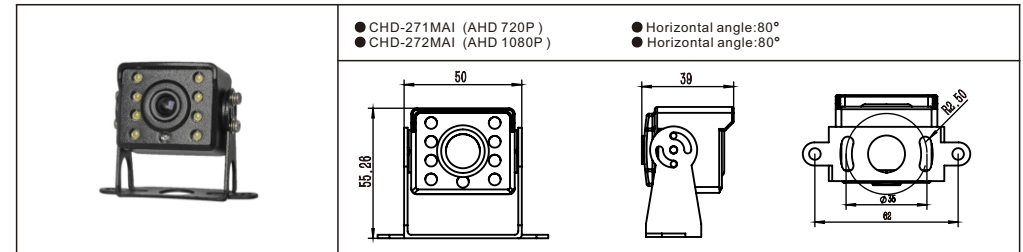
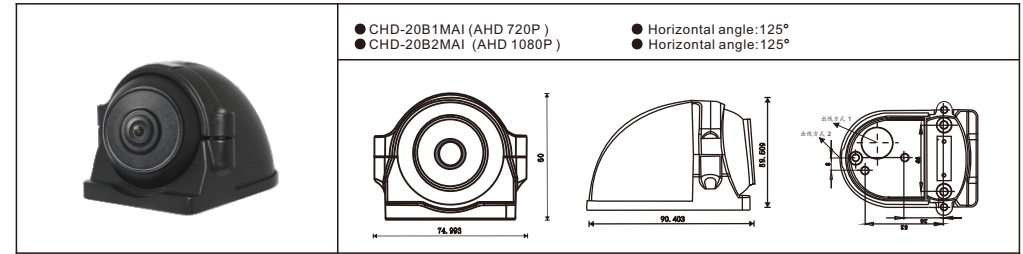

Camera size

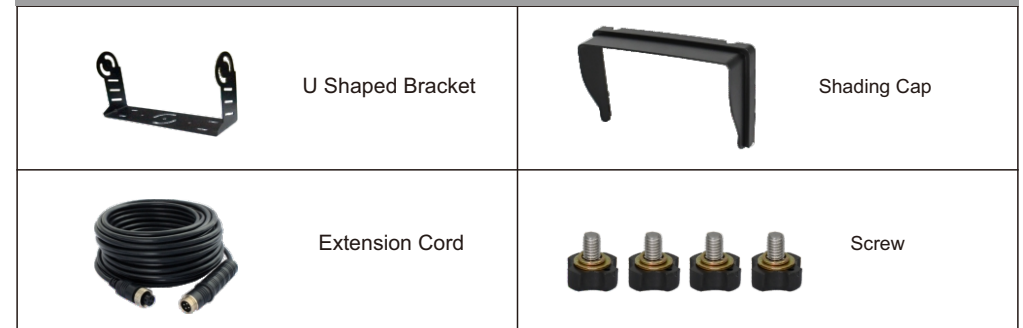

Accessories



Monitor/camera size (mm)

	<p>●MHD-7171J</p>
	<p>●CHD-19B1MAI (AHD 720P) ●CHD-19B2MAI (AHD 1080P)</p> <p>●Horizontal angle : 125° ●Horizontal angle : 125°</p>
	<p>●CHD-101MAI (AHD 720P) ●CHD-102MAI (AHD 1080P)</p> <p>●Horizontal angle:100° ●Horizontal angle:100°</p>
	<p>●CHD-121MAI (AHD 720P) ●CHD-122MAI (AHD 1080P)</p> <p>●Horizontal angle:100° ●Horizontal angle:100°</p>
	<p>●CHD-131MAI (AHD 720P) ●CHD-132MAI (AHD 1080P)</p> <p>●Horizontal angle:100° ●Horizontal angle:100°</p>

Monitoring System Technical Parameters

Display screen	7-inch IPS screen
Resolution	1024×(RGB)×600
Viewing angle (LR/UD)	L/R: 85/85 U/D: 85/85
Contrast	800:1
LED backlight brightness(cd/m ²)	600
Response time (ms)	25
System	PAL/NTSC automatic
Display mode	No Splitter(Work1-2 camera)
Video signal input	AHD1 /AHD2supports 1080P/720P/CVBS signals
Sound warning	DI DI DI (Buzzer)
AI Pre-Warning Signal Input	Green Light - Safe, Yellow Light - Caution, Red Light - Danger
OSD Menu Functions	Mirror/Normal Image Setting, Reverse Delay Setting, Trigger Priority, Multilingual Support
Body line	2 meters Conjoined Line
Shell material	ABS+PC
Load dump	ISO16750-2 Standard (24V System Us=174V, Ri=4Ω, Td=350ms)
Operating temperature	-20℃ ~ +70℃
Storage temperature	-30℃ ~ +80℃
Input power	DC 11~32V
Seismic Rating	GB/T 2423.56-2018 Standard (Random 5G Vibration)
Dimensions(mm)	225X150X85(mm) (with bracket)
Installation bracket	U-shaped bracket
Weight	800g

AI Camera Technical Parameters

Name	AI Backup Camera
Image Sensor	1/2.9 Color CMOS
Effective Pixels	1920(H) X 1080(V)
Field Of View	100°
AI Alarm I/O Output	1-4 Levels PWM
Detection Targets	Pedestrians/Non-Motorized Vehicles
SystemDetection Image Ranging	0-5 Meters (Customizable)
Signal-To-Noise Ratio	≥48dB (AGC Off)
Video output	AHD 1080P
Shell material	Aluminium alloy
Waterproof grade	IP69K
Input power	DC12V±10%
Operating temperature	-20℃ ~ +70℃
Storage temperature	-30℃ ~ +70℃
Seismic Rating	GB/T 2423.56-2018 Standard (Random 5G Vibration)
Body interface	4-core aviation female head

Monitor Key Press Instructions

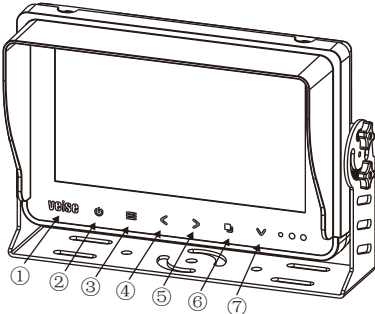
1	Nameplate	
2	Power	
3	Menu	
4	Left key / volume -	
5	Right key / volume +	
6	OK	
7	Down key (channel switching)	

Monitor Menu Operation Instructions

PICTURE



CAR



PIC MODE SYS SETTNG



PICTURE	
BRIGH	50
CONTR	50
SATUR	50
TINT	50



- 1. PICTURE**
BRIGH: The brightness of the display can be adjusted from 0 to 100 bytes, press the </> key to adjust, Default value 50
CONTR: Can be set to adjust the display contrast 0~100 bytes, press </> key to adjust, Default 50.
SATUR: Can be set to adjust the display chromaticity 0~100 bytes, press the </> key to adjust, Default 50.
TINT: Can be set to adjust the display color tone 0~100 bytes, press the </> key to adjust, Default 50.

CAR	
CAR LINE	OFF
CAR DELA	0



- 2. CAR**
CAR LINE: It can be set to turn on/off the AHD1/AHD2 reversing screen to display the reversing auxiliary line, Default is off.
CAR DELA: You can set the AHD1/AHD2 reversing start delay time from 0 to 30 seconds, the default is 0 seconds without delay.

PIC MODE	
ROTATE	0
AHD 1	OFF
AHD 2	OFF



- 3. PIC MODE**
ROTATE: You can set the AHD1/AHD2 screen to flip/mirror up and down respectively, press the </> key to adjust, Default is like.
AHD 1: You can adjust the AHD1 image upright/mirror settings, press the </> key to adjust, the default is upright.
AHD 2: It can be set to adjust the AHD2 image upright/mirror settings, press the </> key to adjust, the default is upright.

SYS SETTNG	
LANGUAGE	ENGLISH
BUZZ	OFF
RESET	<<>
VERSION NUMBER	



- 4. SYS SETTNG**
LANGUAGE: 6 languages for menu items can be set, Chinese, Traditional Chinese, English, Japanese, Korean, Russian, default Chinese
BUZZ: The buzzer sound can be set to turn on/off, Press </> key to adjust, default on;
RESET: You can set the menu item adjustment to return to the initial setting state, press the </> key to adjust.